



■Features

- Output constant Voltage, class 2 multi-channels
- UL, cUL listed, Class 2, Type HL
- Range: 110-277VAC
- Built-in active PFC function
- Efficiency up to 91%
- Protections: short circuit/over load/ over temperature
- Cooling by free air convection
- Full protection metal housing, For dry, damp & wet location (24V); for dry& damp location (48V)
- Dimming function:
 - Phase dimming: work with forward phase /leading edge ,MLV and Reverse phase /trailing edge ,ELV,TRIAC dimmers
 - 0-10V dimming: 0-10V/1-10V/Potentiometer/10V PWM 4 in 1
 - Dimming range: 0-100%
- Suitable for LED lighting and moving sign applications



■Specification

Model		SL-TR-DEM384W-24V	SL-TR-DEM384W-48V
Certificate		UL / cUL / FCC / Class 2 / CE / SELV / RoHS / REACH	
Output	DC Voltage	24V	48V
	Voltage Tolerance	±0.5V	
	Voltage Regulation	±0.5%	
	Rated current	4*4A	4*2A
	Rated power	384W (4*96W)	
	Load Regulation	±1%	
Input	Voltage Range	110-277VAC	
	Frequency Range	47 - 63Hz	
	Power Factor@ full load	0.99@120VAC 0.99@277VAC	0.95@120VAC 0.93@277VAC
	THD(Typ.) @ full load	<20%	
	Efficiency@ full load	88%@120VAC 91%@277VAC	87%@120VAC 89%@277VAC
	AC Current (Max.)	4.1A@100VAC	
	Inrush Current (Typ.)	30A,1.2ms @50%Ipeak	
	Leakage current	<0.5mA	
Protection	Short Circuit	Shut down o/p voltage, re-power on to recover after fault condition is removed	
	Over Load	≤120% Hiccup mode, recovers automatically after fault condition is removed	
	Over temperature	Shell surface temp.100°C±10°C shut down o/p voltage, automatically recover after cooling	
Environment	Working TEMP.	-40~+60°C (see below derating curve)	
	Working Humidity	20 - 95%RH non-condensing	
	Storage TEM.,Humidity	-40 - +80°C,10 - 95% RH non-condensing	
	TEMP.coefficient	±0.03%/°C(0 - 50°C)	
	Vibration	10~500Hz, 5G 12min./1 cycle, period for 72min. each along X,Y,Z axes	
Safety & EMC	Safety standards	UL8750 CAN/CSA-C22.2 No.250.13(US)	
	Withstand voltage	I/P-O/P:1.8KVAC I/P-FG:1.8KVAC O/P-FG:1.8KVAC (US)	
	Isolation resistance	I/P-O/P:100MΩ / 500VDC / 25°C / 70% RH	

	EMC Emission	FCC 47 CFR Part 15, Subpart B(US)
Others	Net Weight	2.85Kg
	Dimension	323*140.4*51.8mm (L*W*H)
	Packing	380*305*160mm 5 pcs/CTN 15.28KG/CTN
Notes	1. All parameters NOT specially mentioned are measured at 120VAC input, rated load and 25°C of ambient temperature. 2. Tolerance: includes set up tolerance and load regulation .	

Derating Curve

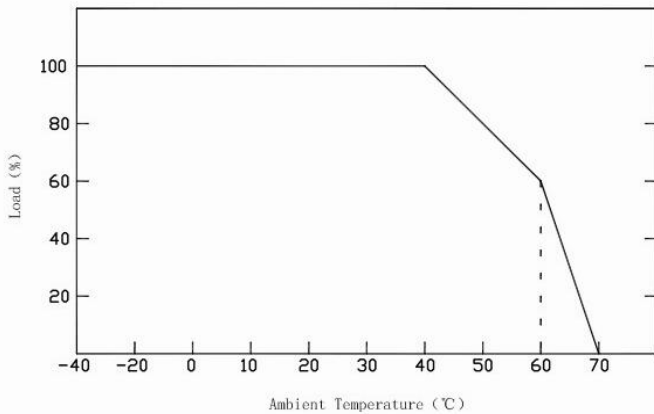

※To extend their life, please refer to the Derating Curve and derate according to the temperature.

Mechanical Specification

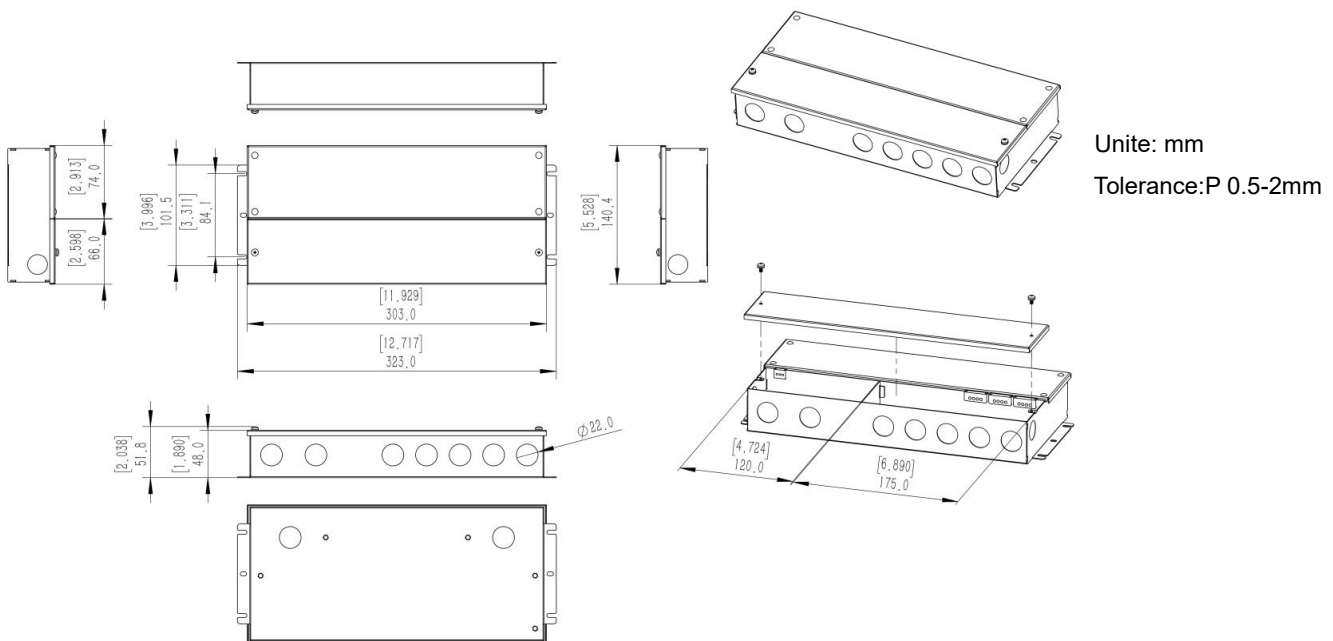

※Input wire 18AWG, Black and White to be connected to AC (L) and (N) ,Green wire go ground .

※Output wire 4*16AWG, Red to LED Positive side (+), Black to LED Negative side (-).

※Dimming cable 4*18AWG, DIM (+) Purple to 0/1-10V dimmer signal (+), DIM (-) Pink to 0/1-10V dimmer signal (-).

※Please DO NOT connect “DIM-“ to “LED-“, “DIM+“ to “ LED+“, or other incorrect connection.

※Please make sure you connect these LED correctly otherwise your product will not function correctly and could be damaged.

AKRAM Phase cut /Triac/0/1-10V 5in1 dimmable driver-PWM output 384W

※Recommended Max. Carrying Current (A) = wire diameter(mm²) x 10A/mm².

For example: 1mm² output cable, Recommended Max. Carrying Current (A) = 1mm² x 10A/mm² =10A.

※Note: Any other requests we can customized.

■ Dimming Operation and Connecting Diagram

※Using two ways of dimming at the same time, you must be assured that LED lighting is up to the max. Brightness then you could operate with the other dimming;

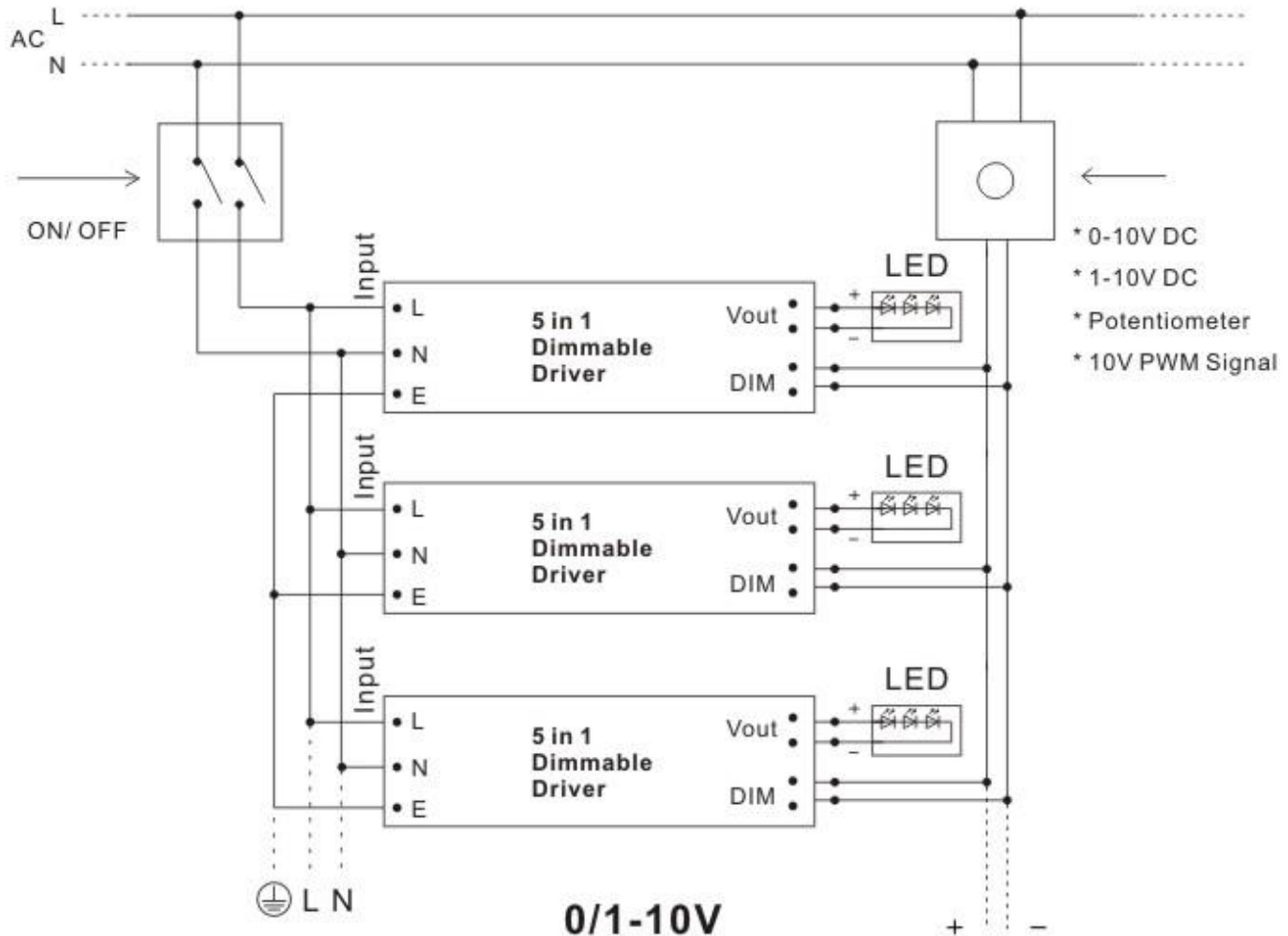

※Using one dimming ---TRIAC/Phase cut dimming

- 1.The Pulse-Width Modulation (PWM) of output voltage can be adjusted through input terminal of the AC phase line(L) by connection a phase /Triac dimmer of lighting system.
- 2.Working with forward phase /leading edge ,MLV and Reverse phase /trailing edge ,ELV,TRIAC dimmers
- 3.Min loading is about 10%
- 4.Please try to use dimmers with power at least 1.5 times as the output power of the driver.

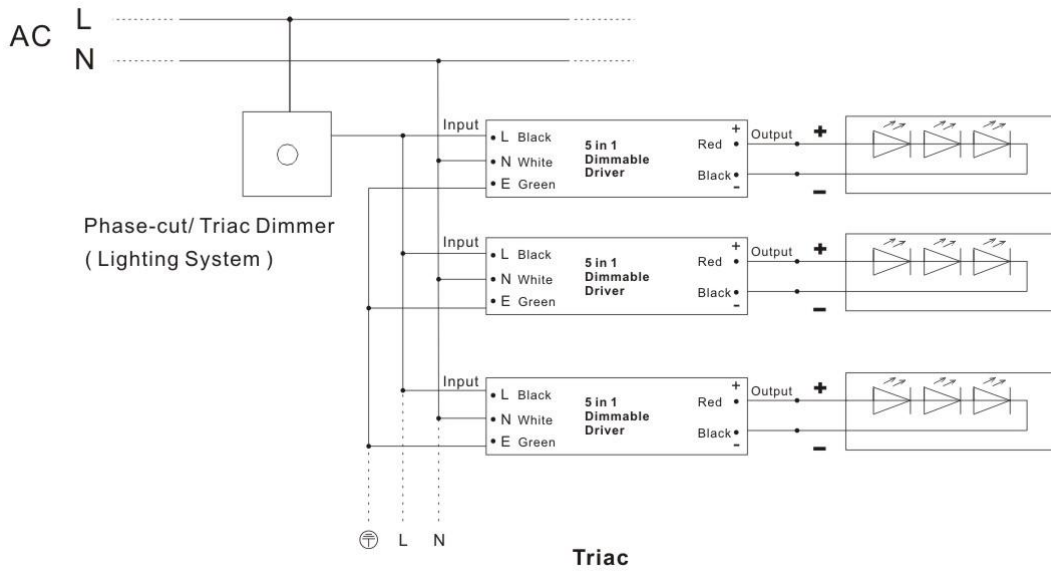

※ 0-10/1-10V dimming

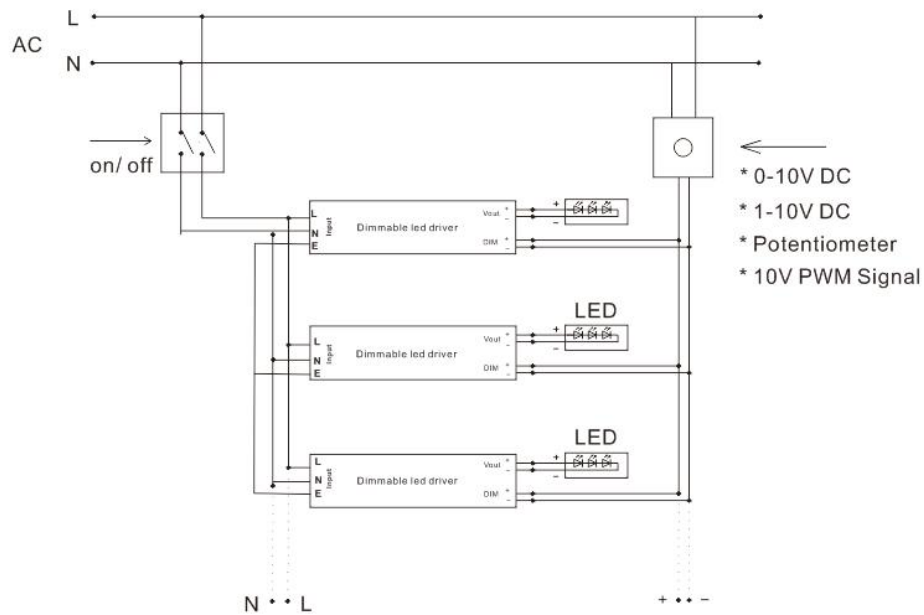

Diagram 1

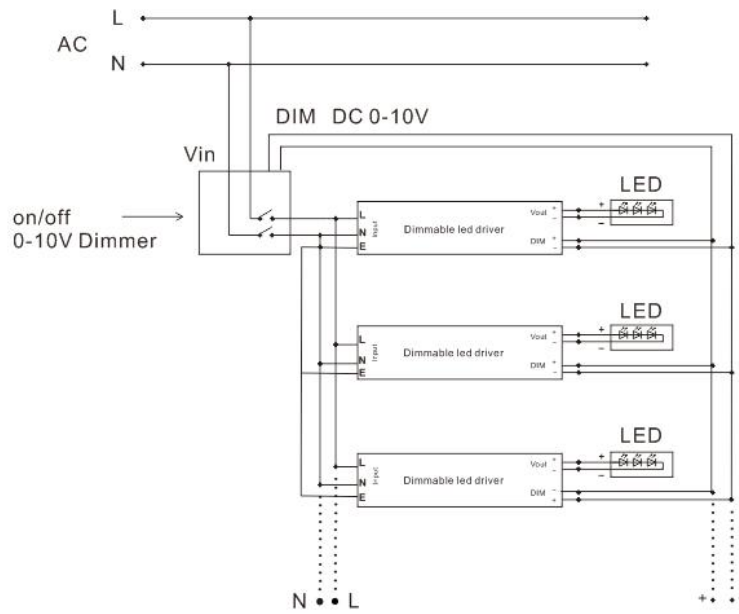

Diagram 2

※To extend their life, please refer to the Derating Curve and derate according to the temperature.

■ Instruction:

- 1) This driver should be installed by qualified and professional person;
- 2) Please make sure the driver is installed with adequate ventilation around it to allow for heat dissipation.
- 3) Ensure that wiring is correct before test in order to avoid light and power supply damage;
- 4) If driver Cannot work normally, don't maintain privately; Have any question, please contact us.